

EXS-117E

EXS-SERIES

904, PRAGATI TOWER, 26, RAJENDRA PLACE,
New Delhi-110 008 FAX : 91-11-25751872
PH.: 25711757,25718363,25739438,25743910
Website : www.vibgyorinternational.com
E-mail : vibgyor@bol.net.in
info@vibgyorinternational.com

SPECIFICATION

STRAP WIDTH	9-15mm
SPEED	30 Straps/MIN (60HZ.), 28 Straps/MIN(50HZ.)
POWER SUPPLY	100, 110, 220, 230, 240V., 50/60HZ., 1-Phase
POWER CONSUMPTION	0.72 KW
MACHINE TENSION	5-70KGS
MACHINE DIMENSION	1330mm(L) x 640mm(W) x 1830mm (H)
MACHINE WEIGHT	240 KGS

OPTION: SEE CHART BELOW

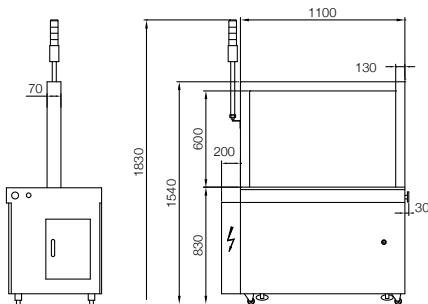

Arch Size Available

H \ W	850	1050	1250
400	•	•	•
600	S	•	•
800	•	•	•
1000	•	•	•

S Standard Arch Size
• Arch Available

